

**UOB Transaction Banking**



# **Interbank GIRO Upgrade BIB Guide**

23 July 2015

# Contents

	Page
1. Background	1
2. Making Interbank Transfers	1
2.1 Single GIRO Transfers	1
2.2 Bulk GIRO Payments	2
2.3 Payment Templates	2
3. Account Statement	3
3.1 BIB Statement – Bulk Transactions (Fixed Length)	3
3.2 BIB Statement – Bulk Transactions (CSV)	4
3.3 MT940 Statement	5
3.4 Extracts of MT940 Statement Sample	6
4. Account Statement – DDA Reference	7
4.1 BIB Statement (Fixed Length and CSV)	7
4.2 MT940 Statement	7
4.3 Extracts of MT940 Statement Sample	8

## 1. Background

From 23 March 2015, the current interbank GIRO system will be upgraded as part of an industry wide to serve you better. There will be improvements to how you send GIRO payments. To ease your account reconciliation, additional transaction details will be provided for bulk payments in the Account Statement. Please refer to the instructions in this Guide on how to take advantage of the new features of the upgraded GIRO in BIB. For more information on the upgraded GIRO, please click [here](#) or visit uob.com.sg

## 2. Making Interbank Transfers

### 2.1 Single GIRO Transfers

Please select 'All Other Branches' (Branch code 999) instead of selecting branch code from the drop-down list with the following exceptions:

- Oversea-Chinese Banking Corporation Limited (OCBC), Hongkong and Shanghai Banking Corporation Limited (HSBC) and State Bank of India (SBI). For these 3 banks, you need to select the branch code.
- For all 9 digit POSBANK accounts, you need to select the branch code, '081'.

**Funds Transfer**

- ▶ Inter Account
- ▶ **Inter Bank**
- ▶ FAST Payment

<a href="#">CHO HUNG BANK</a>	<a href="#">8615</a>
<a href="#">CIMB BANK BERHAD</a>	<a href="#">7986</a>
<a href="#">CITIBANK NA</a>	<a href="#">7214</a>
<a href="#">COMMERZBANK AG</a>	<a href="#">8606</a>
<a href="#">CREDIT AGRICOLE CORPORATE AND INVESTMENT BANK</a>	<a href="#">7135</a>
<a href="#">CTBC BANK CO., LTD</a>	<a href="#">9353</a>
<a href="#">DBS BANK / POSBANK</a>	<a href="#">7171</a>

**Inter Bank Funds Transfer**  
03 Mar 2015 7:37 pm Singapore Time

Required fields are indicated by \*.

For payment to any UOB accounts, please use the Inter Account Funds Transfer module under Account Services menu.

Transaction Option	:	<input checked="" type="radio"/> Immediate
	:	<input type="radio"/> Transfer Date (Up to 90 days) 04 Mar 2015
Transfer From	:	Please Select
Transfer To	:	
Bank Code (4 digits)	:	<input type="text"/> * Please click <a href="#">here</a> for the Bank and Branch Code.
Branch Code (3 digits)	:	<input type="text"/> *
Account Number	:	<input type="text"/> *
Payee Name	:	<input type="text"/> *
Credit Amount	:	SGD <input type="text"/> *
Details	:	

To proceed, please click on a Branch Name or Branch Code.

The Bank code for CITIBANK NA is 7214.

Branches for CITIBANK NA	Branch Code
<a href="#">ALL OTHER BRANCHES</a>	<a href="#">999</a>

## 2.2 Bulk GIRO Payments

Please select 'All Other Branches' (Branch code 999) instead of selecting branch code from the drop-down list with the following exceptions:

- For OCBC, HSBC and SBI, you need to select the branch code.
- For UOB/FEB Bulk Services online templates, you need to select the branch code.
- For all 9 digit POSBANK accounts, you need to select the branch code, '081'.



**Bulk Services**

- Bulk Payment**
- Payment
- Payroll
- Payroll 2
- Bulk Collection**
- IBG Collection

<a href="#">CHO HUNG BANK</a>	8615
<a href="#">CIMB BANK BERHAD</a>	7986
<a href="#">CITIBANK NA</a>	7214
<a href="#">COMMERZBANK AG</a>	8606
<a href="#">CREDIT AGRICOLE CORPORATE AND INVESTMENT BANK</a>	7135
<a href="#">CTBC BANK CO., LTD</a>	9353
<a href="#">DBS BANK / POSBANK</a>	7171

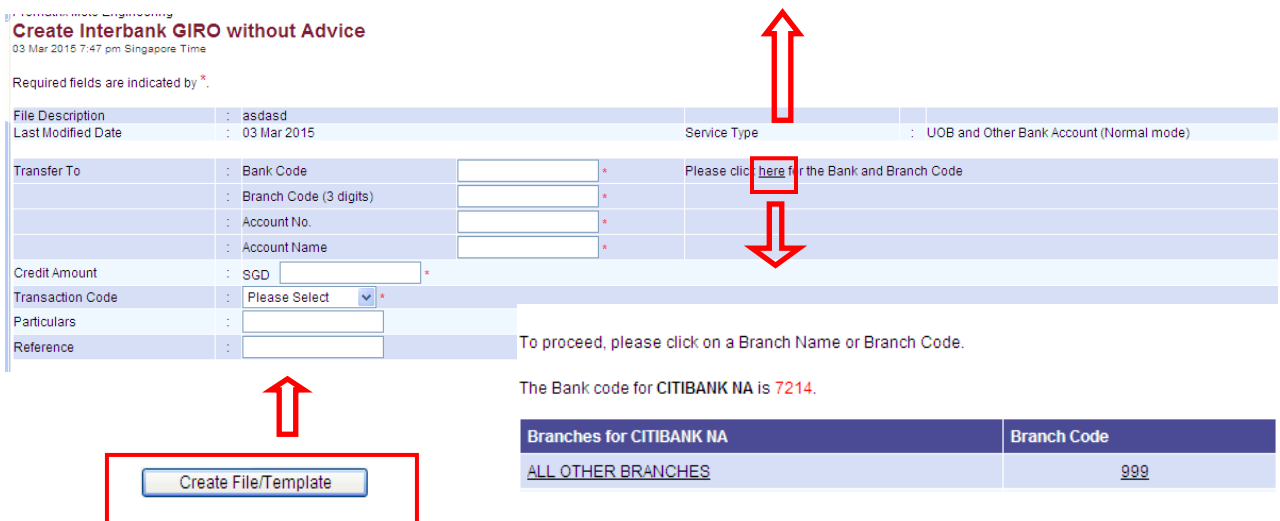
**Create Interbank GIRO without Advice**  
03 Mar 2015 7:47 pm Singapore Time

Required fields are indicated by \*.

File Description : asdasd  
Last Modified Date : 03 Mar 2015  
Service Type : UOB and Other Bank Account (Normal mode)

Transfer To : Bank Code  \*  
Branch Code (3 digits)  \*  
Account No.  \*  
Account Name  \*

Credit Amount : SGD  \*

Transaction Code : Please Select  \*

Particulars :

Reference :

Please click [here](#) for the Bank and Branch Code

To proceed, please click on a Branch Name or Branch Code.

The Bank code for CITIBANK NA is 7214.

Branches for CITIBANK NA	Branch Code
<a href="#">ALL OTHER BRANCHES</a>	999

[Create File/Template](#)

If you upload files via 'File Upload,' please continue to use the existing IBG file format until further advice from UOB.

## 2.3 Payment Templates

If you have already created payment templates for single and bulk payments such as Bulk Payroll using various branch codes of the payee bank, please continue to use these templates. There is no need to replace the branch codes in your templates.

### 3. Account Statement

From 23 March 2015, the transaction amount and service charge will be shown as separate entries in your Account Statement for bulk transactions. Transaction description is also more detailed. This will help ease your account reconciliation. Please refer to the statement format changes below:

#### 3.1 BIB Statement – Bulk Transactions (Fixed Length)

Transaction Type	Statement Format	Transaction Details Shown in Statement		
		Before 23 Mar 2015	From 23 Mar 2015	
<b>Bulk Payment/Payroll</b>				
Transaction Amount	Transaction Description: Your Reference: Our Reference: Transaction Text:	Misc Debit - GIRO PAYMENTS ROS01117	BULK - GIRO  ROS01117 PAYMENTS	Transaction Description Bank Reference Transaction Type
Service Charge	Transaction Description: Your Reference: Our Reference: Transaction Text:	Not shown. Service Charge is debited together with transaction amount as one entry.	SVC Chg  ROS01117 PAYMENTS	Transaction Description Bank Reference Transaction Type
<b>Bulk Collection</b>				
Transaction Amount	Transaction Description: Your Reference: Our Reference: Transaction Text:	Misc Credit - GIRO COLLECTIONS ROS01117	BULK - GIRO  ROS01117 COLLECTIONS	Transaction Description Bank Reference Transaction Type
Service Charge	Transaction Description: Your Reference: Our Reference: Transaction Text:	Not shown. Service Charge is debited together with transaction amount as one entry.	Serv Charge  ROS01117 COLLECTIONS	Transaction Description Bank Reference Transaction Type

### 3.2 BIB Statement – Bulk Transactions (CSV)

#### Format Before 23 March 2015

3	Account Number	Type			Account Currency	Account Name	Date From	Date To
4								
5	351-351-XXX-X	Current A/C			SGD	Payroll Account	01-Jan-15	31-Jan-15
6								
7	Total Withdrawal Amount				3,089.25			
8	Total Deposit Amount				40,160.22			
9								
10	Date	Description			Withdrawal	Deposit	Ledger Balance	
44	27-Jan-15	Misc Debit-GIRO	PAYMENTS	ROS03629	4.4	0	9,532,953.30	

#### Format From 23 March 2015

3	Account Number	Type			Account Currency	Account Name	Date From	Date To
4								
5	351-351-XXX-X	Current A/C			SGD	Payroll Account	01-Jan-15	31-Jan-15
6								
7	Total Withdrawal Amount				3,089.25			
8	Total Deposit Amount				40,160.22			
9								
10	Date	Description			Withdrawal	Deposit	Ledger Balance	
48	27-Jan-15	Bulk - GIRO	ROS03629	PAYMENTS	4	0	9,532,953.60	
49	27-Jan-15	SVC Chg	ROS03629	PAYMENTS	0.4	0	9,532,947.10	
60	28-Jan-15	Bulk - GIRO	ROS03630	COLLECTIONS	0	2.2	9,572,972.00	
61	28-Jan-15	Serv Charge	ROS03630	COLLECTIONS	0.4	0	9,572,971.60	

### 3.3 MT940 Statement

If you are receiving MT940 through Reports > File Download module, please refer to the statement format changes below:

Transaction Type	Statement Format	Transaction Details Shown in Statement		
		Before 23 Mar 2015	From 23 Mar 2015	
<b>Bulk Payment/Payroll</b>				
Transaction Amount	Tag61 Subfield 6 (Txn Code) Tag61 Subfield 7 (Owner's Ref) Tag61 Subfield 8 (Institution's Ref) Tag61 Subfield 9 (Supp Details)	NIBG ROS01117 PAYMENTS	NIBG NIL ROS01117 PAYMENTS	Transaction Code NIL Bank Reference Transaction Type
Service Charge	Tag61 Subfield 6 (Txn Code) Tag61 Subfield 7 (Owner's Ref) Tag61 Subfield 8 (Institution's Ref) Tag61 Subfield 9 (Supp Details)	Charge is debited together with principal as one entry.	NSVC NIL ROS01117 PAYMENTS	Transaction Code NIL Bank Reference Transaction Type
<b>Bulk Collection</b>				
Transaction Amount	Tag61 Subfield 6 (Txn Code) Tag61 Subfield 7 (Owner's Ref) Tag61 Subfield 8 (Institution's Ref) Tag61 Subfield 9 (Supp Details)	NIBG ROS01117 COLLECTIONS	NIBG NIL ROS01117 COLLECTIONS	Transaction Code NIL Bank Reference Transaction Type
Service Charge	Tag61 Subfield 6 (Txn Code) Tag61 Subfield 7 (Owner's Ref) Tag61 Subfield 8 (Institution's Ref) Tag61 Subfield 9 (Supp Details)	Charge is debited together with principal as one entry.	NSVC NIL ROS01117 COLLECTIONS	Transaction Code NIL Bank Reference Transaction Type

Please refer to the following diagram for extracts of the MT940 statement sample.

### 3.4 Extracts of MT940 Statement Sample

#### Before 23 March 2015

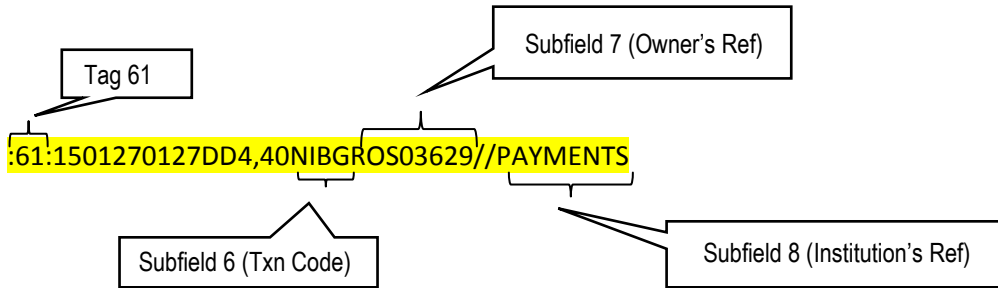

Figure 1: Service charge is debited together with transaction amount as one entry

#### From 23 March 2015

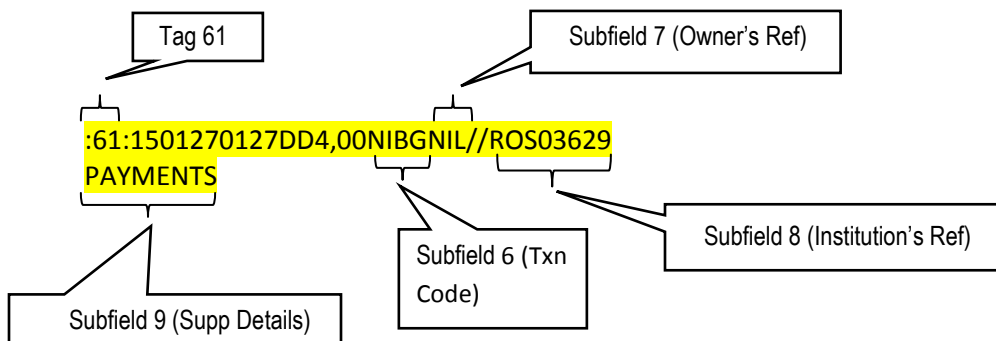

Figure 2: Transaction Amount

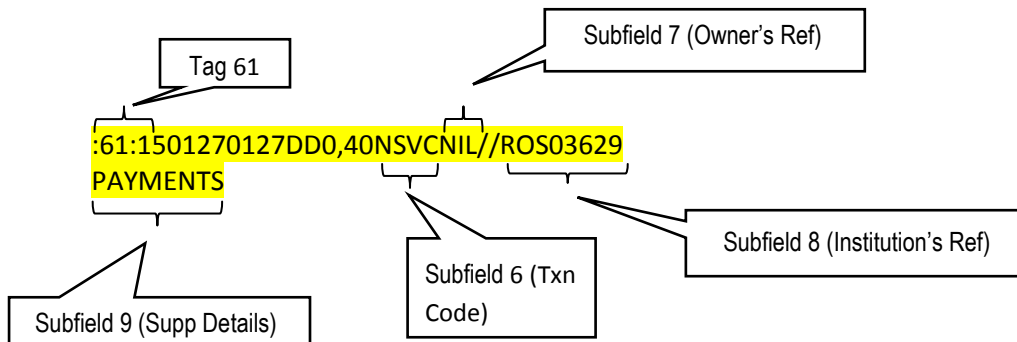

Figure 3: Service Charge

The contents of this Guide are provided for general information only, and are subject to change, and may be modified, deleted and changed from time to time and at any time at the sole discretion of the UOB Group. The copyright and other intellectual property in the Guide is owned by the UOB Group. No other part or parts hereof may be used, reproduced, distributed, published, modified, displayed, broadcasted, hyperlinked, or transmitted in any manner or by any means or stored in an information retrieval system without the UOB Group's prior written permission.



#### 4. Account Statement – DDA Reference

From 3 August 2015, your UOB statement will reflect the DDA Reference for incoming Direct Debit from your Billing Organisation. It will replace the Purpose Code Description that is currently reflected on your statement under “Our Reference” field. Please see below table for the changes. The changes are highlighted in yellow.

##### 4.1 BIB Statement (Fixed Length and CSV)

Transaction Type	Statement Format	Transaction Details Shown in Statement	
		Before 3 Aug 2015	From 3 Aug 2015
<b>Incoming Direct Debit - FAST</b>			
Transaction Amount	Transaction Description: Your Reference: Our Reference: Transaction Text:	INWARD DR - FAST KFEngineering OTHR Other Invoice1234	INWARD DR - FAST KFEngineering OTHR <b>DDAKF</b> Invoice1234
Transaction Description Sender's Name Purpose Code + DDA Reference Beneficiary Reference			
<b>Incoming Direct Debit – GIRO</b>			
Transaction Amount	Transaction Description: Your Reference: Our Reference: Transaction Text:	INWARD DR - GIRO KFEngineering OTHR Other Invoice1234	INWARD DR - GIRO KFEngineering OTHR <b>DDAKF</b> Invoice1234
Transaction Description Sender's Name Purpose Code + DDA Reference Beneficiary Reference			

##### 4.2 MT940 Statement

Transaction Type	Statement Format	Transaction Details Shown in Statement	
		Before 3 Aug 2015	From 3 Aug 2015
<b>Incoming Direct Debit - FAST</b>			
Transaction Amount	Tag61 Subfield 6 (Txn Code) Tag61 Subfield 7 (Owner's Ref) Tag61 Subfield 8 (Institution's Ref) Tag61 Subfield 9 (Supp Details)	NIBF KFEngineering OTHR Other Invoice1234	NIBF KFEngineering OTHR <b>DDAKF</b> Invoice1234
Transaction Code Sender's Name Purpose Code + DDA Reference Beneficiary Reference			
<b>Incoming Direct Debit - GIRO</b>			
Transaction Amount	Tag61 Subfield 6 (Txn Code) Tag61 Subfield 7 (Owner's Ref) Tag61 Subfield 8 (Institution's Ref) Tag61 Subfield 9 (Supp Details)	NIBG KFEngineering OTHR Other Invoice1234	NIBG KFEngineering OTHR <b>DDAKF</b> Invoice1234
Transaction Code Sender's Name Purpose Code + DDA Reference Beneficiary Reference			

Please refer to the following diagram for extracts of MT940 statement sample.

### 4.3 Extracts of MT940 Statement Sample

#### Before 3 Aug 2015

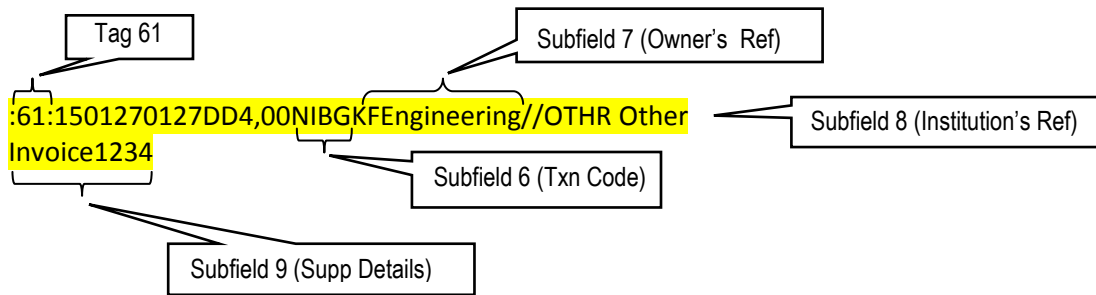

#### From 3 Aug 2015

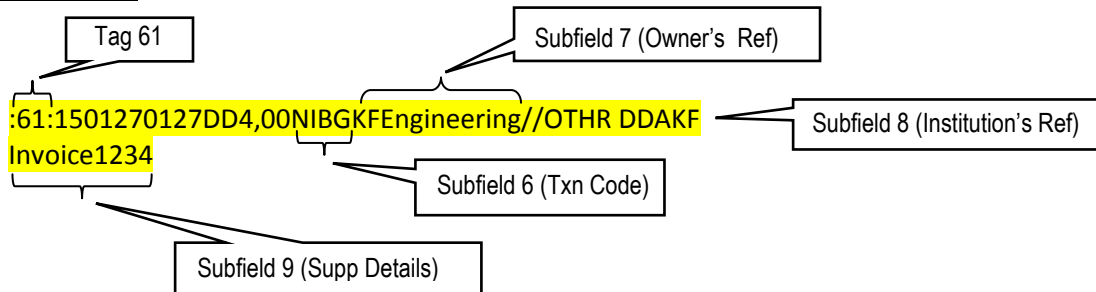

The contents of this Guide are provided for general information only, and are subject to change, and may be modified, deleted and changed from time to time and at any time at the sole discretion of the UOB Group. The copyright and other intellectual property in the Guide is owned by the UOB Group. No other part or parts hereof may be used, reproduced, distributed, published, modified, displayed, broadcasted, hyperlinked, or transmitted in any manner or by any means or stored in an information retrieval system without the UOB Group's prior written permission.

United Overseas Bank Limited Co. Reg. No. 193500026Z